

HEATRAESADIA

SMARTER | CLEANER | WARMER

PremierPlus Unvented Hot Water Cylinder Installation and User Manual

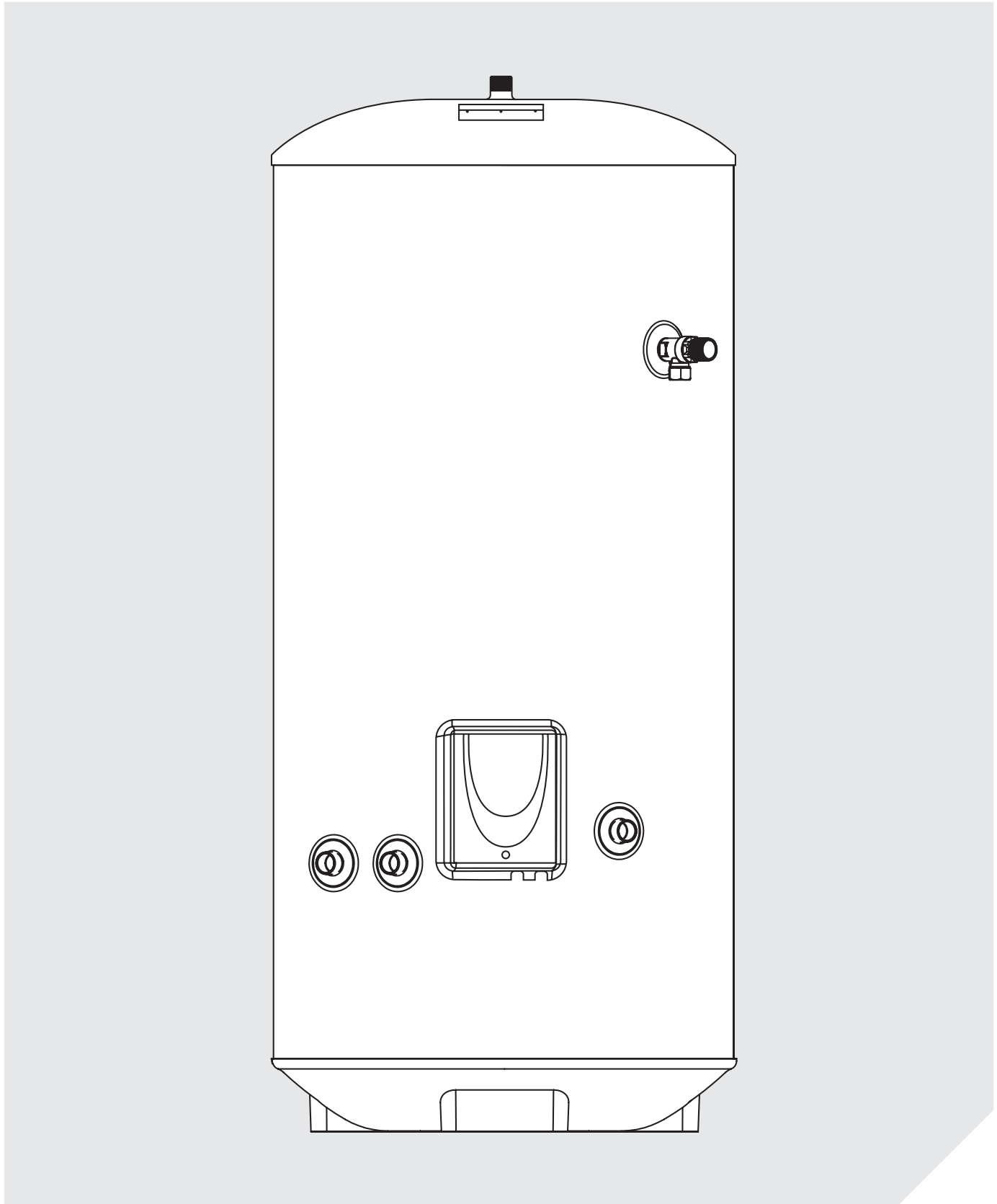

Contents

1. Introduction.....	3
1.1 General	3
1.2 Symbols used	3
1.3 Abbreviations	3
1.4 Liabilities.....	3
2. Safety	4
2.1 General safety warnings	4
2.2 Recommendations.....	4
2.3 Specific safety instructions	4
3. Technical specifications.....	5
3.1 Technical data	5
3.2 Dimensions and connections.....	7
3.3 Electrical diagram(s).....	8
4. Description of the product.....	10
4.1 General description	10
4.2 Operation principle	10
4.3 Main components.....	10
4.4 Standard delivery	10
5. Before installation.....	10
5.1 Installation regulations	10
5.2 Installation requirements.....	10
5.3 Choice of location.....	11
6. Installation	11
6.1 General	11
6.2 Water connections.....	12
6.3 Electrical connections.....	18
6.4 Filling the installation	18
7. Commissioning	19
7.1 General	19
7.2 Checklist before commissioning	19
7.3 Commissioning procedure.....	19
8. Operation	20
8.1 General	20
9. Maintenance.....	21
9.1 General	21
9.2 Standard inspection & maintenance operations.....	21
10. Troubleshooting.....	22
10.1 Fault finding	22
11. Decommissioning	23
11.1 Decommissioning procedure.....	23
12.1 Spare parts list.....	23
Benchmark checklist.....	25
Commissioning & service records.....	26
Warranty	27

THE BENCHMARK SCHEME



Benchmark places responsibilities on both manufacturers and installers. The purpose is to ensure that customers are provided with the correct equipment for their needs, that it is installed, commissioned and serviced in accordance with the manufacturer's instructions by competent persons and that it meets the requirements of the appropriate Building Regulations and relevant electrical qualifications. The Benchmark Checklist can be used to demonstrate compliance with Building Regulations and should be provided to the customer for future reference. Installers are required to carry out installation, commissioning and servicing work in accordance with the Benchmark Code of Practice which is available from the Heating and Hotwater Industry Council who manage and promote the Scheme. Visit www.centralheating.co.uk for more information.

1. Introduction

1.1 General

The following instructions are offered as a guide to the user and installer.

The installation must be carried out by a competent plumbing and electrical installer in accordance with Building Regulation G3 (England and Wales), Technical Standard P3 (Scotland) or Building Regulation P5 (Northern Ireland) and the Water Fitting Regulations (England and Wales) or Water Byelaws (Scotland).

1.2 Symbols used

In these instructions, various risk levels are employed to draw the user's attention to particular information. In doing so we wish to safeguard the user, avoid hazards and guarantee the correct operation of the appliance.



DANGER

Risk of a dangerous situation causing serious physical injury.



WARNING

Risk of dangerous situation causing slight physical injury.



CAUTION

Risk of material damage.



Signals important information.

1.3 Abbreviations

- ▶ T&P - Temperature & Pressure relief valve
- ▶ PRV - Pressure Reducing Valve
- ▶ Prv - Pressure relief valve

1.4 Liabilities

Manufacturers liability

Our products are manufactured in compliance with the requirements of the various applicable European Directives.

This appliance complies with the requirements of the CE marking directive.

In the interest of UK customers, we are continuously endeavouring to make improvements in product quality. All the specifications stated in this document are therefore subject to change without notice.

Our liability as the manufacturer may not be invoked in the following cases:

- ▶ Failure to abide by the instructions on using the appliance.
- ▶ Faulty or insufficient maintenance of the appliance.
- ▶ Failure to abide by the instructions on installing the product.

Installer's liability

The installer is responsible for the installation and the commissioning of the appliance. The installer must respect the following instructions:

- ▶ Read and follow the instructions given in the manuals provided with the appliance.
- ▶ Carry out installation in compliance with the prevailing legislation and standards.
- ▶ Perform the initial start up and carry out any checks necessary.
- ▶ Complete the commissioning checklist.
- ▶ Explain the installation to the user.
- ▶ If maintenance is necessary, warn the user of the obligation to check the appliance and maintain it in good working order.
- ▶ Give all the instruction manuals to the user.

Users liability

To guarantee optimum operation of the appliance, the user must respect the following instructions:

- ▶ Read and follow the instructions given in the manuals provided with the appliance.
- ▶ Call on qualified professionals to carry out installation and initial start up.
- ▶ Get your installer to explain your installation to you.
- ▶ Have your required checks and services done.
- ▶ Keep the instruction manuals in good condition and close to the appliance.

 This appliance can be used by children aged from 8 years and above and persons with reduced physical sensory or mental capabilities or lack of experience and knowledge if they have been given supervision or instruction concerning use of the appliance in a safe way and understand the hazards involved. Children shall not play with the appliance. Cleaning and user maintenance shall not be made by children without supervision.

Children must be supervised to ensure they do not play with the appliance.

2. Safety

2.1 General safety warnings



DANGER

This cylinder is unvented and as such becomes pressurised when in operation. The combination of pressurisation and hot water could lead to serious physical injury if the safety instructions in this manual are not adhered to.



WARNING

- ▶ Only competent persons having received adequate training are permitted to work on the appliance and the installation.
- ▶ Do not tamper with any of the safety valves or controls supplied with the cylinder.
- ▶ Before any work, switch off the mains supply to the appliance and the mains water supply.
- ▶ Do not switch on if there is a possibility that the water in the cylinder is frozen.



CAUTION

Do not operate immersion heaters until the cylinder has been filled with water.

2.2 Recommendations



WARNING

When handling the unit, take appropriate precautions for the weight of the unit. Weights can be found in section 3, table 1 & 2, page 5 & 6.



CAUTION

Annual maintenance is recommended by a competent person.

2.3 Specific safety instructions



WARNING

- ▶ If water discharges from the temperature/pressure relief valve on the cylinder shut down the boiler/immersion heaters. Do not turn off any water supply. Contact a competent installer for unvented water heaters to check the system.
- ▶ Do not tamper with any of the safety valves fitted to the system. If a fault is suspected contact a competent installer.
- ▶ DO NOT bypass the thermal cut-out(s) in any circumstances.

The HWA Charter Statement requires that all members adhere to the following:

- ▶ To supply fit for purpose products clearly and honestly described.
- ▶ To supply products that meet, or exceed appropriate standards and building and water regulations.
- ▶ To provide pre and post sales technical support.
- ▶ To provide clear and concise warranty details to customers.

3. Technical specifications

3.1 Technical data:

	100 indirect	120 indirect	150 indirect	170 indirect	210 indirect	250 indirect	250 indirect	300 indirect	300 indirect
Max direct kW rating @240v	3	3	3	3	3	3	6	3	6
Coil surface area m2	0.58	0.58	0.72	0.79	0.79	0.79	0.79	0.79	0.79
Coil rating (kW)	15l/min	15.2	15.4	15.9	17.3	19.2	18.6	18.6	18.8
Indirect heat time (mins)	15l/min	24	24	29	30	34	42	42	49
Heat loss (kWh in 24h) / Day		1.14	1.25	1.45	1.63	1.91	2.22	2.22	2.52
Weight full (kg)		125	147	184	203	251	300	300	360
Weight empty (kg)		25	27	31	33	41	50	50	60
Max supply pressure	1.6MPa (16 bar)								
Max design pressure	0.8MPa (8 bar)								
Max operating pressure (PRV)	0.35MPa (3.5 bar)								
Expansion relief valve setting	0.6MPa (6 bar)								
T&P valve setting (RWC PTEM 550853)	1.0MPa (10 bar)/90°C								
Maximum primary pressure	1.0MPa (10 bar)								
Pressure drop across coil	0.02MPa (0.2bar)								

Notes:

Table 1: Technical data - Indirect

1. Indirect cylinders tested in accordance with BS EN 12897:2006.
2. Heat up time from cold through 45°C, based on a flow temperature of 80°C +/- 2°C & normal volume.
3. Although the primary coil pressure rating is 1.0MPa (10bar) the 2 port zone valve and coil compression nuts supplied with the cylinder is only rated 0.86MPa (8.6 bar). If the cylinder is to be plumbed into a system delivering 1.0MPa (10 bar) a suitable 2 port zone valve and the coil compression nuts supplied will have to be sourced.

Direct									
Supplier's name or trade mark	Premier Plus								
Supplier's model identifier	PP100E	PP120E	PP150E	PP170E	PP210E	PP250E	PP250E 9Kw	PP300E	PP300E 9kW
Storage volume V in litres	100.0	120.0	150.0	170.0	210.0	250.0	250.0	300.0	300.0
Mixed water at 40 °C V40 in litres	143	180	234	265	332	395	395	464	464
The declared load profile	M	M	L	L	XL	XL	XL	XL	XL
The water heating energy efficiency class of the model	C	C	C	C	C	D	D	D	D
The water heating energy efficiency in %	36.2	36.0	37.3	37.1	38.1	37.4	37.4	36.6	36.6
The annual electricity consumption in kWh	1418	1424	2741	2759	4395	4478	4573	4478	4573
Daily fuel consumption Q fuel in kWh	6.640	6.680	12.730	12.840	20.300	20.790	21.350	20.790	21.350
The thermostat temperature settings of the water heater, as placed on the market by the supplier	60°C								
Specific precautions that shall be taken when the water heater is assembled, installed or maintained and disposed of at end of life	See section 2 to 8								

Indirect									
Model(s)	PP100B	PP120B	PP150B	PP170B	PP210B	PP250B	PP300B	PP250B 6Kw	PP300B 6kW
The water heating energy efficiency class of the model	B	B	C	C	C	D	D	D	D
Storage volume V in litres	100.0	120.0	150.0	170.0	210.0	250.0	300.0	250.0	300.0
Standing loss in W	48.0	52.0	60.0	68.0	80.0	93.0	105.0	93.0	105.0

Table: Technical parameters in accordance with European Commission regulations 814/2013 and 812/2013

	100 direct	120 direct	150 direct	170 direct	210 direct	250 direct	250 direct	300 direct	300 direct
Max direct kW rating @240v	3	3	3	3	3	3	9	3	9
Direct heat time (based on max kW rating in mins)	99	121	152	173	215	257	88	310	105
Heat loss (kWh in 24h)	1.14	1.25	1.45	1.63	1.91	2.22	2.22	2.52	2.52
Weight full (kg)	123	145	178	199	246	295	295	355	355
Weight empty (kg)	23	25	28	29	36	45	45	55	55
Max supply pressure	1.6MPa (16 bar)								
Max design pressure	0.8MPa (8 bar)								
Max operating pressure (PRV)	0.35MPa (3.5 bar)								
Max expansion vessel charge pressure	0.35MPa (3.5bar)								
Expansion relief valve setting	0.6MPa (6 bar)								
T&P valve setting (RWC PTEM 550853)	1.0MPa (10 bar)/90°C								

Table 2: Technical data - Direct

Notes:

1. Direct cylinders tested in accordance with EN 50440 for efficiency parameters
2. Heat up time from cold through 45°C, based on a flow temperature of 80°C +/- 2°C & normal volume.

3.2 Dimensions and connections

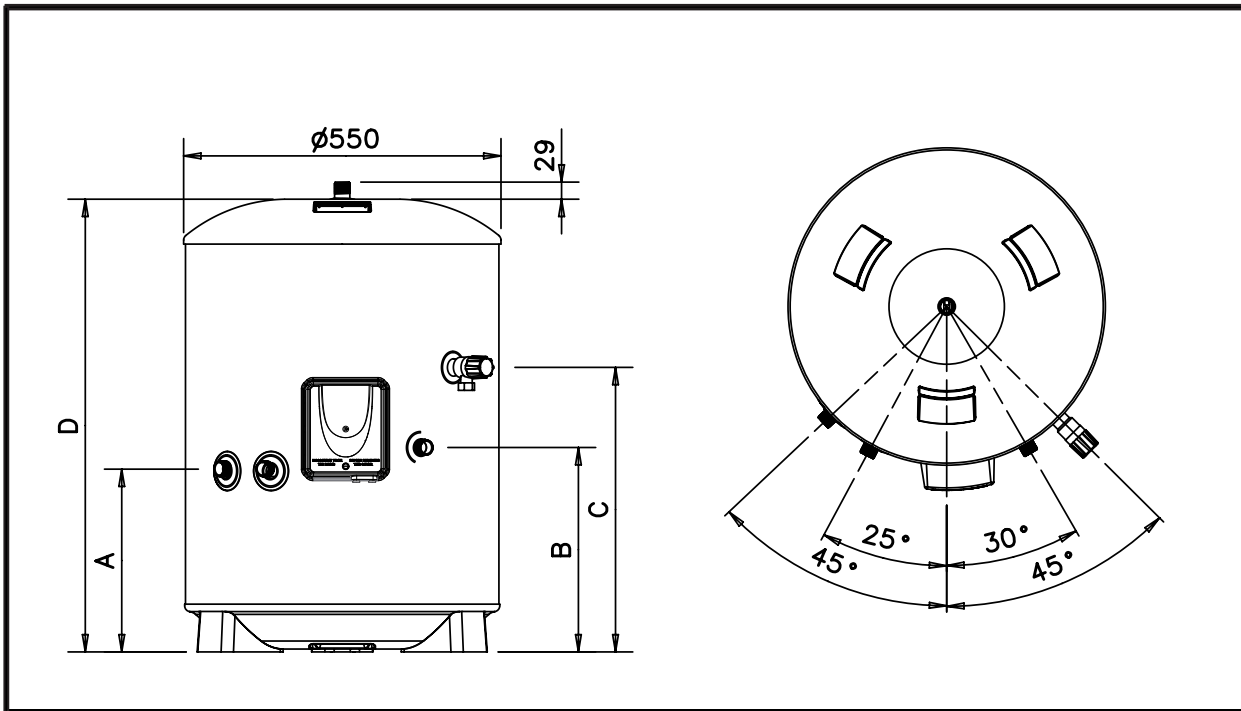

Figure 1: General dimensions - Direct

Item	100E	120E	150E	170E	210E	250E	300E
B	306	306	306	306	306	306	306
C	493	616	800	925	1184	1437	1751
D	784	906	1090	1216	1474	1726	2040

Table 3: General dimensions table - Direct

Item	100B	120B	150B	170B	210B	250B	300B
A	315	315	315	315	315	315	315
B	354	354	354	354	354	354	354
C	500	616	800	927	1184	1439	1754
D	784	906	1090	1216	1474	1726	2040

Table 4: General dimensions table - Indirect

3.3 Electrical diagram(s)

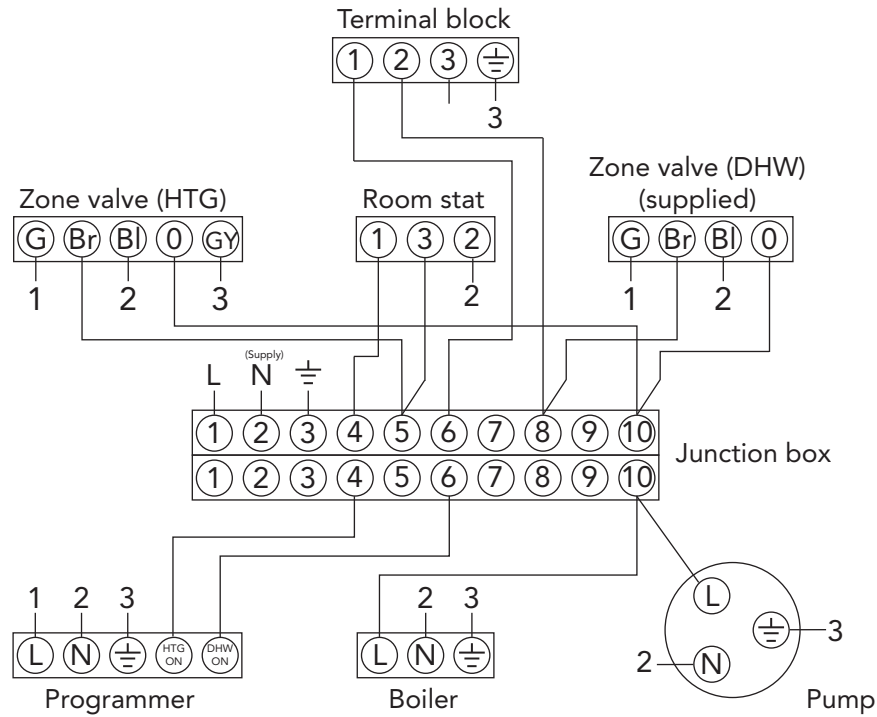

NOTES: Control terminal numbering may differ from those shown.
 Refer to instructions with controls selected.
 A double pole isolating switch must be installed in the mains supply.
 All earth connections must be connected back to the mains earth supply.

Figure 2: Schematic wiring diagram - basic 2 x 2 port valve system

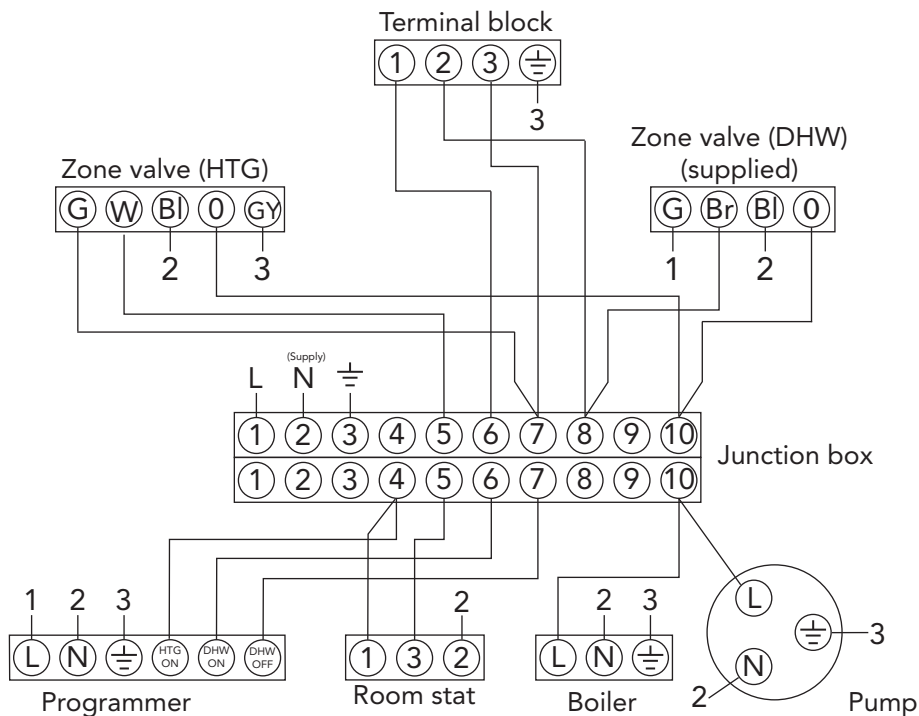

NOTES: Control terminal numbering may differ from those shown.
 Refer to instructions with controls selected.
 A double pole isolating switch must be installed in the mains supply.
 All earth connections must be connected back to the mains earth supply.

Figure 3: Schematic wiring diagram - 3 port mid position system

Control Housing Details

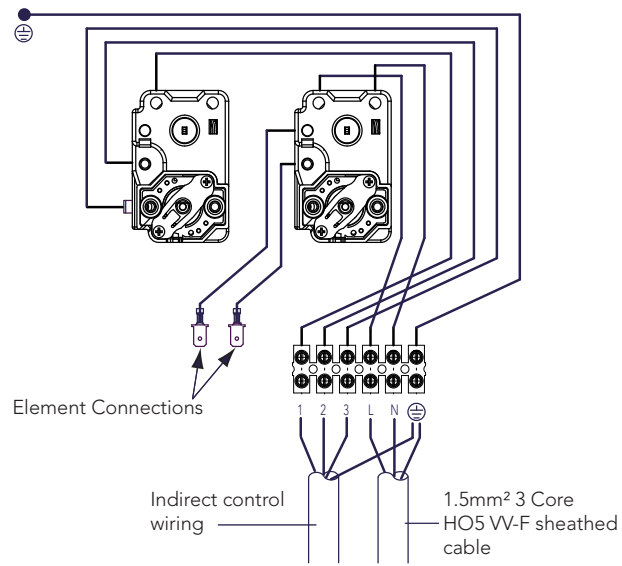

Figure 4: Indirect wiring schematic

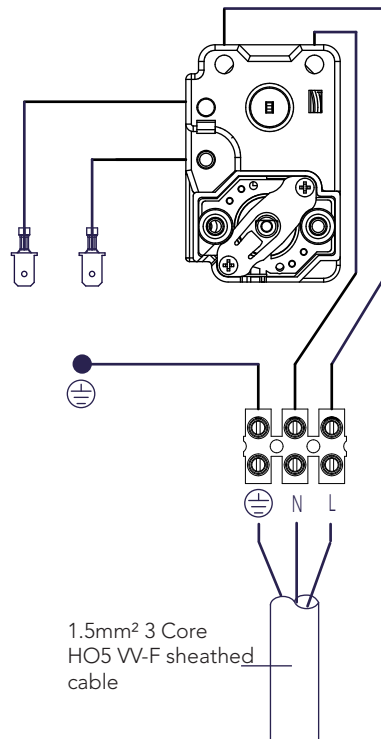

Figure 5: Direct wiring schematic

4. Description of the product

4.1 General description

This product is a purpose designed unvented water heater. The unit has a stainless steel inner vessel, which ensures an excellent standard of corrosion resistance. The outer casing is a combination of resilient thermoplastic mouldings and pre-coated steel. All products are insulated with CFC free polyurethane foam to give good heat loss protection.

The unit is supplied complete with all the necessary safety and control devices needed to allow connection to the cold water mains. All these components are preset and should not be tampered with.

4.2 Operation principle

The unvented cylinder is used to heat and store hot water for use in domestic installations.

Depending on the model the water can be heated directly using Immersion heater(s) or indirectly through a coil in the unit using an indirect heat source.

4.3 Main connections

See Figures 7 : Main Schematic on page 12

4.4 Standard delivery

The delivery includes:

- ▶ Cylinder
- ▶ Factory fitted immersion heater(s) and thermal controls
- ▶ Factory fitted Temperature and Pressure Relief Valve (set at 90°C / 1 Mpa (10bar))
- ▶ Factory fitted indirect thermostat and thermal cut-out
- ▶ Literature pack
Instructions (inc benchmark commissioning checklist & service record)
- ▶ Cold water control pack
Combination valve (inc pressure reducing valve, pressure relief valve and check valve)
Expansion vessel and mounting bracket
Tundish
Nuts & Olives
- ▶ 2 port zone valve (indirect only)

5. Before installation

5.1 Installation regulations



WARNING

Installation of the appliance must be carried out by a qualified engineer in accordance with prevailing and national regulations as listed below.

- ▶ Building Regulations G3
- ▶ The Building Standards (Scotland)
- ▶ The Building Regulations (Northern Ireland)
- ▶ I.E.E Electrical Regs
- ▶ UK Water Regulations

5.2 Installation requirements

Water supply

In an unvented system the pressure and flowrate is directly related to the incoming water supply. For this reason it is recommended that the maximum water demand is assessed and the water supply checked to ensure this demand can be satisfactorily met.

- ▶ We suggest the minimum supply requirements should be 0.15MPa (1.5 bar) pressure and 20 litres per minute flow rate. However, at these values outlet flow rates may be poor if several outlets are used simultaneously.
- ▶ A 22mm cold water supply is recommended, however, if a smaller supply exists, which provides sufficient flow, this may be used (although more flow noise may be experienced).
- ▶ The higher the available pressure and flow rate the better the system performance.
- ▶ See table 1 & 2 on pages 5 & 6 for cylinder operating pressures. This is controlled by the cold water combination valve assembly.
- ▶ The water supply must be of wholesome water quality (Fluid Category 1 as defined by the Water Supply Regulations 1999).

Outlet/terminal fittings (taps, etc.)

- ▶ The cylinder can be used with most types of terminal fittings.
- ▶ Outlets situated higher than the cylinder will give outlet pressures lower than that at the heater, a 10m height difference will result in a 1 bar pressure reduction at the outlet.
- ▶ All fittings, pipework and connections must have a rated pressure of at least 6 bar (dependant on cylinder being fitted) at 80°C.
- ▶ It is advantageous in many mixer showers to have a balanced hot and cold water supply, in these instances a balanced cold water connection is available on the combination inlet valve.

Limitations

The cylinder should not be used in association with any of the following:

- ▶ Solid fuel boilers or any other boiler in which the energy input is not under effective thermostatic control, unless additional and appropriate safety measures are installed.
- ▶ Ascending spray type bidets or any other class 1 back syphonage risk requiring that a type A air gap be employed.
- ▶ Steam heating plants unless additional and appropriate safety devices are installed.
- ▶ Situations where maintenance is likely to be neglected or safety devices tampered with.
- ▶ Water supplies that have either inadequate pressure or where the supply may be intermittent.
- ▶ Situations where it is not possible to safely pipe away any discharge from the safety valves.
- ▶ In areas where the water consistently contains a high proportion of solids, e.g. suspended matter that could block the strainer, unless adequate filtration can be ensured.
- ▶ In areas where the water supply contains chloride levels that exceed 250mg/l.

5.3 Choice of location

The cylinder must be vertically floor mounted. Although location is not critical, the following points should be considered:

- ▶ The cylinder should be sited to ensure minimum dead leg distances, particularly to the point of most frequent use.
- ▶ Avoid siting where extreme cold temperatures will be experienced. All exposed pipe work should be insulated.
- ▶ The discharge pipework from the safety valves must have minimum fall of 1:200 from the unit and terminate in a safe and visible position.
- ▶ Access to associated controls and immersion heaters must be available for the servicing and maintenance of the system. Where these controls are installed against a wall a minimum distance of 250mm must be left.
- ▶ Ensure that the floor area for the cylinder is level and capable of permanently supporting the weight when full of water (see table 1 & 2, page 5 & 6 for weights).
- ▶ Prior to installation the unit should be stored and transported in an area free from excessive damp or humidity. The Unit should be stored in a frost free environment.

6. Installation

6.1 General

After reading the previous sections in this booklet and choosing a good location for the unit please install, paying attention to the following hydraulic, electrical and commissioning sections.

Boiler selection

- ▶ The boiler should have a control thermostat and non self-resetting thermal cut-out and be compatible with unvented storage water heaters.
- ▶ Can be a sealed system or open vented type - maximum primary pressure 3 bar.
- ▶ The primary flow from the boiler must be pumped. Gravity circulation will not work due to the special design of the primary heat exchanger. It is recommended that an air bleed point or automatic air vent is incorporated in the primary return pipework close to the unvented system.
- ▶ The boiler cannot be vented through the cylinder.

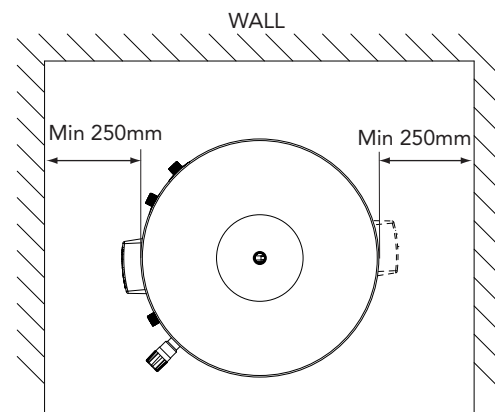

Figure 6: Access schematic (not to scale)

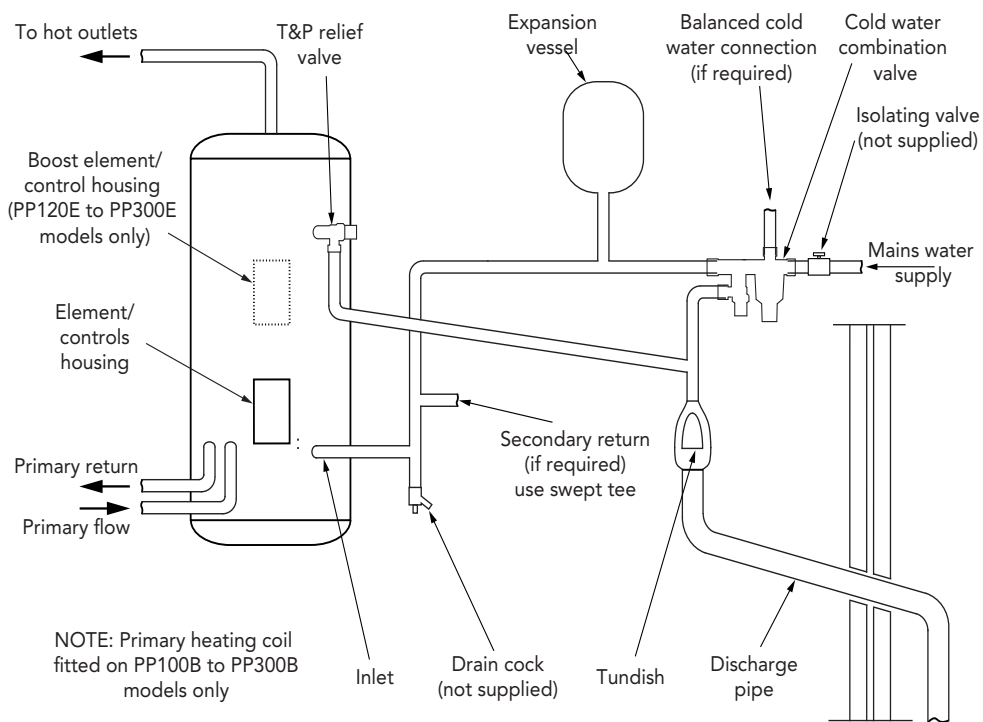

Figure 7: Typical installation schematic (not to scale)

6.2 Water connections



WARNING

- ▶ Under no circumstances should the factory fitted temperature/pressure relief valve be removed other than by a competent person. To do so will invalidate any guarantee or claim.
- ▶ The cold water combination valve assembly must be fitted on the mains water supply to the cylinder.
- ▶ No control or safety valves should be tampered with or used for any other purpose.
- ▶ The discharge pipe should not be blocked or used for any other purpose.
- ▶ The tundish should not be located adjacent to any electrical components.

- ▶ All pipe fittings are made via 22mm compression fittings directly to the unit (nuts and olives supplied). The fittings are also threaded 3/4" BSP male parallel should threaded pipes connections be required.
- ▶ A stopcock or servicing valve should be incorporated into the cold water supply to enable the cylinder to be isolated from the mains supply for maintenance or servicing..
- ▶ A suitable draining tap should be installed in the cold water supply to the cylinder between the expansion valve and the heater at a lower level as possible.
- ▶ It is recommended that the outlet point of the drain pipework be at least 1 metre below the level of the heater (this can be achieved by attaching a hose to the drain tap outlet spigot)

Refer to the installation schematic (fig 7 above) for details on the pipework layout. Specific details for the discharge pipework layout is also provided in figure 10 on page 17

Cold water control pack



CAUTION

- ▶ Flush supply pipework before connection to remove all flux and debris prior to fitting the inlet controls. Failure to do this may result in irreparable damage to the controls and will invalidate any warranty.
- ▶ No other valves should be placed between the cold water combination valve and the cylinder.
- ▶ The cold water combination valve is installed as a complete one-piece unit. The valve incorporates the pressure reducer, strainer, expansion valve and check valve.
- ▶ The pressure setting is set to 3.5 bar.
- ▶ The valve can be fitted in any orientation to suit the installation as long as the valve is installed with the direction of flow arrows pointing in the correct direction.
- ▶ The expansion relief valve should be installed with the discharge pipework in either the horizontal position or facing downwards, if fitted inverted, debris may be deposited on the seat and cause fouling of the seat.

- ▶ Where discharge pipework is difficult to attain, the local building control officer from the local council should be sought for advice as this falls under G3 guidelines and is not down to the manufacturer of unvented systems
- ▶ The second outlet is for balanced cold water supply, if not used blank off (plug supplied)

Primary circuit control

- ▶ The 2 port motorised valve supplied with the cylinder **MUST** be fitted on the primary flow to the cylinder heat exchanger and wired such that in the event of the cylinder overheating it will close the primary circuit.
- ▶ Primary circulation to the cylinder heat exchanger must be pumped; gravity circulation **WILL NOT WORK**.
- ▶ It is recommended that an air bleed or automatic air vent is incorporated in the primary return pipe work close to the unit.
- ▶ Boiler flow temperature should be set to 82° (maximum flow temperature to primary heat exchanger 88°C).

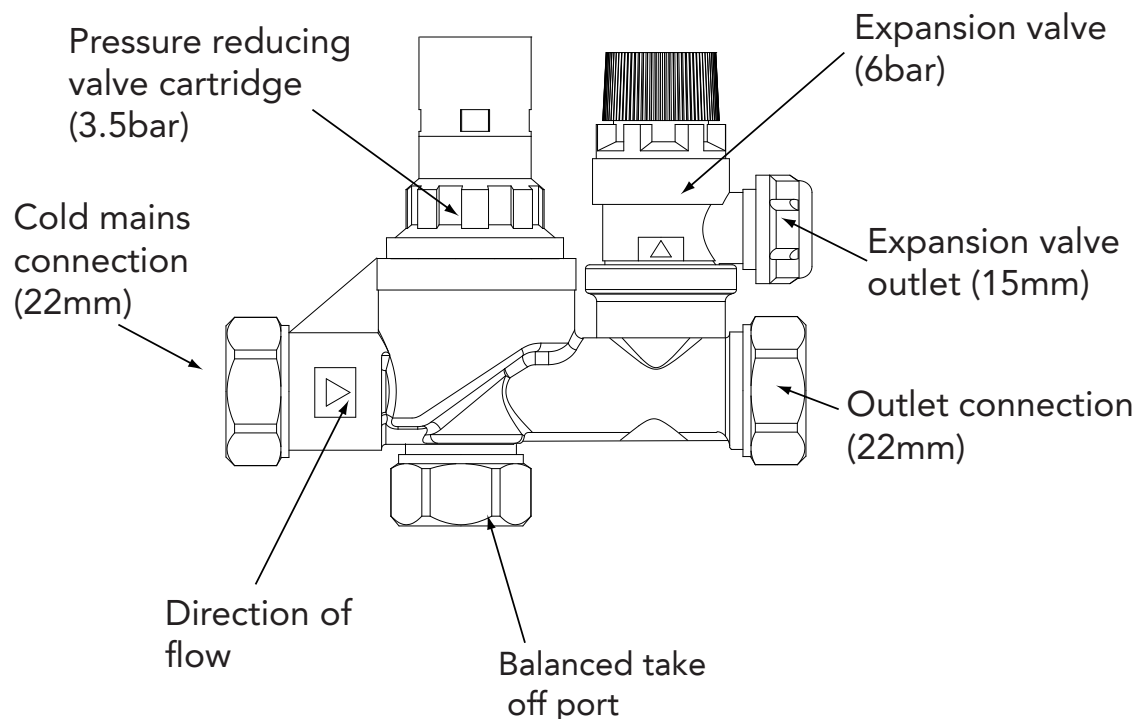

Figure 8: Combination inlet valve

Expansion vessel

The expansion vessel accommodates expansion that results from heating the water inside the unit.

- ▶ The expansion vessel is pre-charged at 3.5bar.
- ▶ The expansion vessel must be connected between the expansion valve and the cylinder.
- ▶ The location of the expansion vessel should allow access to recharge the pressure as and when necessary, this can be done using a normal car foot pump.
- ▶ It is recommended that the expansion vessel is adequately supported. An expansion vessel wall mounting bracket is supplied for this purpose and should be fitted.

Secondary circulation

If secondary circulation is required it is recommended that it be connected to the cylinder as shown (see fig. 9, below).

- ▶ The secondary return pipe should be in 15mm pipe and incorporate a check valve to prevent backflow.
- ▶ A suitable WRAS approved bronze circulation pump will be required.
- ▶ On large systems, due to the increase in system water content, it may be necessary to fit an additional expansion vessel to the secondary circuit. This should be done if the capacity of the secondary circuit exceeds 10 litres.

Pipe capacity (copper):

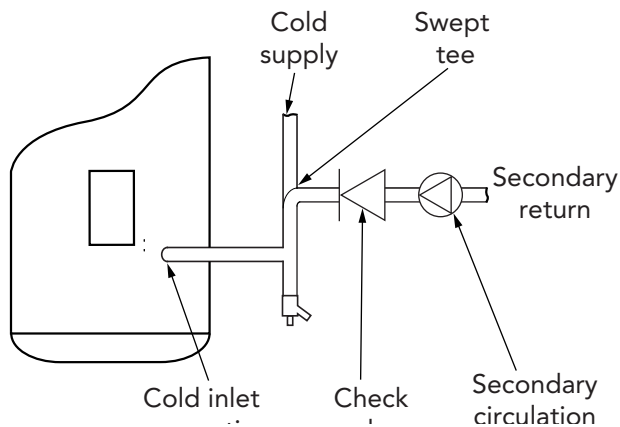

Figure 9: Secondary circulation schematic

15mm O.D. = 0.13 l/m (10 litres = 77m)

22mm O.D. = 0.38 l/m (10 litres = 26m)

28mm O.D. = 0.55 l/m (10 litres = 18m)

Note: Plastic pipe capacities may be reduced due to thicker wall sections.

i In direct electric installations where a secondary circulation is required particular attention should be paid by the installer to maintain the returning water temperature (guidelines state that a minimum of 55°C return temperature is advisable). Factors such as, but not limited to, secondary circulation flow rates, minimising heat loss of all secondary circuit pipework and timed operation during periods of high demand are critical to the correct operation and longevity of the heating element(s) and thermostats.

Discharge

It is a requirement of Building Regulation G3 that any discharge from an unvented system is conveyed to where it is visible, but will not cause danger to persons in or about the building. The tundish and discharge pipes should be fitted in accordance with the requirements and guidance notes of Building Regulation G3. The G3 Requirements and Guidance section 3.50 - 3.63 are reproduced in the following sections of this manual. For discharge pipe arrangements not covered by G3 Guidance advice should be sought from your local Building Control Officer. Any discharge pipe connected to the pressure relief devices (expansion valve and temperature/pressure relief valve) must be installed in a continuously downward direction and in a frost free environment.

Water may drip from the discharge pipe of the pressure relief device. This pipe must be left open to the atmosphere. The pressure relief device is to be operated regularly to remove lime deposits and to verify that it is not blocked.

G3 REQUIREMENT

"...there shall be precautions...to ensure that the hot water discharged from safety devices is safely conveyed to where it is visible but will not cause danger to persons in or about the building."

The following extract is taken from the latest G3 Regulations

Discharge pipes from safety devices

Discharge pipe D1

3.50 Each of the temperature relief valves or combined temperature and pressure relief valves specified in 3.13 or 3.17 should discharge either directly or by way of a manifold via a short length of metal pipe (D1) to a tundish.

3.51 The diameter of discharge pipe (D1) should be not less than the nominal outlet size of the temperature relief valve.

3.52 Where a manifold is used it should be sized to accept and discharge the total discharge from the discharge pipes connected to it.

3.53 Where valves other than the temperature and pressure relief valve from a single unvented hot water system discharge by way of the same manifold that is used by the safety devices, the manifold should be factory fitted as part of the hot water storage system unit or package.

Tundish

3.54 The tundish should be vertical, located in the same space as the unvented hot water storage system and be fitted as close as possible to, and lower than, the valve, with no more than 600mm of pipe between

the valve outlet and the tundish (see fig 10).

Note: To comply with the Water Supply (Water Fittings) Regulations, the tundish should incorporate a suitable air gap.

3.55 Any discharge should be visible at the tundish. In addition, where discharges from safety devices may not be apparent, e.g. in dwellings occupied by people with impaired vision or mobility, consideration should be given to the installation of a suitable safety device to warn when discharge takes place, e.g. electronically operated.

Discharge pipe D2

3.56 The discharge pipe (D2) from the tundish should:

- (a) have a vertical section of pipe at least 300mm long below the tundish before any elbows or bends in the pipework (see fig. 10); and
- (b) be installed with a continuous fall thereafter of at least 1 in 200.

3.57 The discharge pipe (D2) should be made of:

- (a) metal; or
- (b) other material that has been demonstrated to be capable of safely withstanding temperatures of the water discharged and is clearly and permanently marked to identify the product and performance standard (e.g. as specified in the relevant part of BS 7291).

3.58 The discharge pipe (D2) should be at least one pipe size larger than the nominal outlet size of the safety device unless its total equivalent hydraulic resistance exceeds that of a straight pipe 9m long, i.e. for discharge pipes between 9m and 18m the equivalent resistance length should be at least two sizes larger than the nominal outlet size of the safety device; between 18 and 27m at least 3 sizes larger, and so on; bends must be taken into account in calculating the flow resistance. See Fig 10, Table 5 and the worked example.

Note: An alternative approach for sizing discharge pipes would be to follow Annex D, section D.2 of BS 6700:2006 Specification for design, installation, testing and maintenance of services supplying water for domestic use within buildings and their curtilages.

3.59 Where a single common discharge pipe serves more than one system, it should be at least one pipe size larger than the largest individual discharge pipe (D2) to be connected.

3.60 The discharge pipe should not be connected to a soil discharge stack unless it can be demonstrated that the soil discharge stack is capable of safely withstanding temperatures of the water discharged, in which case, it should:

- (a) contain a mechanical seal, not incorporating a water trap, which allows water into the branch pipe

without allowing foul air from the drain to be ventilated through the tundish;

(b) be a separate branch pipe with no sanitary appliances connected to it;

(c) if plastic pipes are used as branch pipes carrying discharge from a safety device they should be either polybutylene (PB) to Class S of BS 7291-2:2006 or cross linked polyethylene (PE-X) to Class S of BS 7291-3:2006; and

(d) be continuously marked with a warning that no sanitary appliances should be connected to the pipe.

Note:

1. Plastic pipes should be joined and assembled with fittings appropriate to the circumstances in which they are used as set out in BS EN ISO 1043-1.

2. Where pipes cannot be connected to the stack it may be possible to route a dedicated pipe alongside or in close proximity to the discharge stack.

Termination of discharge pipe

3.61 The discharge pipe (D2) from the tundish should terminate in a safe place where there is no risk to persons in the vicinity of the discharge.

3.62 Examples of acceptable discharge arrangements are:

(a) to a trapped gully with the end of the pipe below a fixed grating and above the water seal;

(b) downward discharges at low level; i.e. up to 100mm above external surfaces such as car parks, hard standings, grassed areas etc. are acceptable providing that a wire cage or similar guard is positioned to prevent contact, whilst maintaining visibility; and

(c) discharges at high level: e.g. into a metal hopper and metal downpipe with the end of the discharge pipe clearly visible or onto a roof capable of withstanding high temperature discharges of water and 3m from any plastic guttering system that would collect such discharges.

3.63 The discharge would consist of high temperature water and steam. Asphalt, roofing felt and non-metallic rainwater goods may be damaged by such discharges.

Worked example of discharge pipe sizing

Fig. 10: shows a G1/2 temperature relief valve with a discharge pipe (D2) having 4 No. elbows and length of 7m from the tundish to the point of discharge.

From Table 5:

Maximum resistance allowed for a straight length of 22mm copper discharge pipe (D2) from a G1/2 temperature relief valve is 9.0m.

Subtract the resistance for 4 No. 22mm elbows at 0.8m each = 3.2m

Therefore the permitted length equates to: 5.8m

5.8m is less than the actual length of 7m therefore calculate the next largest size.

Maximum resistance allowed for a straight length of 28mm pipe (D2) from a G1/2 temperature relief valves equates to 18m.

Subtract the resistance of 4 No. 28mm elbows at 1.0m each = 4.0m

Therefore the maximum permitted length equates to: 14m

As the actual length is 7m, a 28mm (D2) copper pipe will be satisfactory.

Valve Outlet Size	Minimum Size Of Discharge Pipe D1	Minimum Size Of Discharge Pipe D2 From Tundish	Maximum Resistance Allowed, Expressed As A Length Of Straight Pipe (I.E. No Elbows Or Bends)	Resistance Created By Each Elbow Or Bend
G1/2	15mm	22mm 28mm 35mm	up to 9m up to 18m up to 27m	0.8m 1.0m 1.4m
G3/4	22mm	28mm 35mm 42mm	up to 9m up to 18m up to 27m	1.0m 1.4m 1.7m
G1	28mm	35mm 42mm 54mm	up to 9m up to 18m up to 27m	1.4m 1.7m 2.3m

Table 5: Sizing of copper discharge pipe (D2) for common temperature relief valve outlet sizes

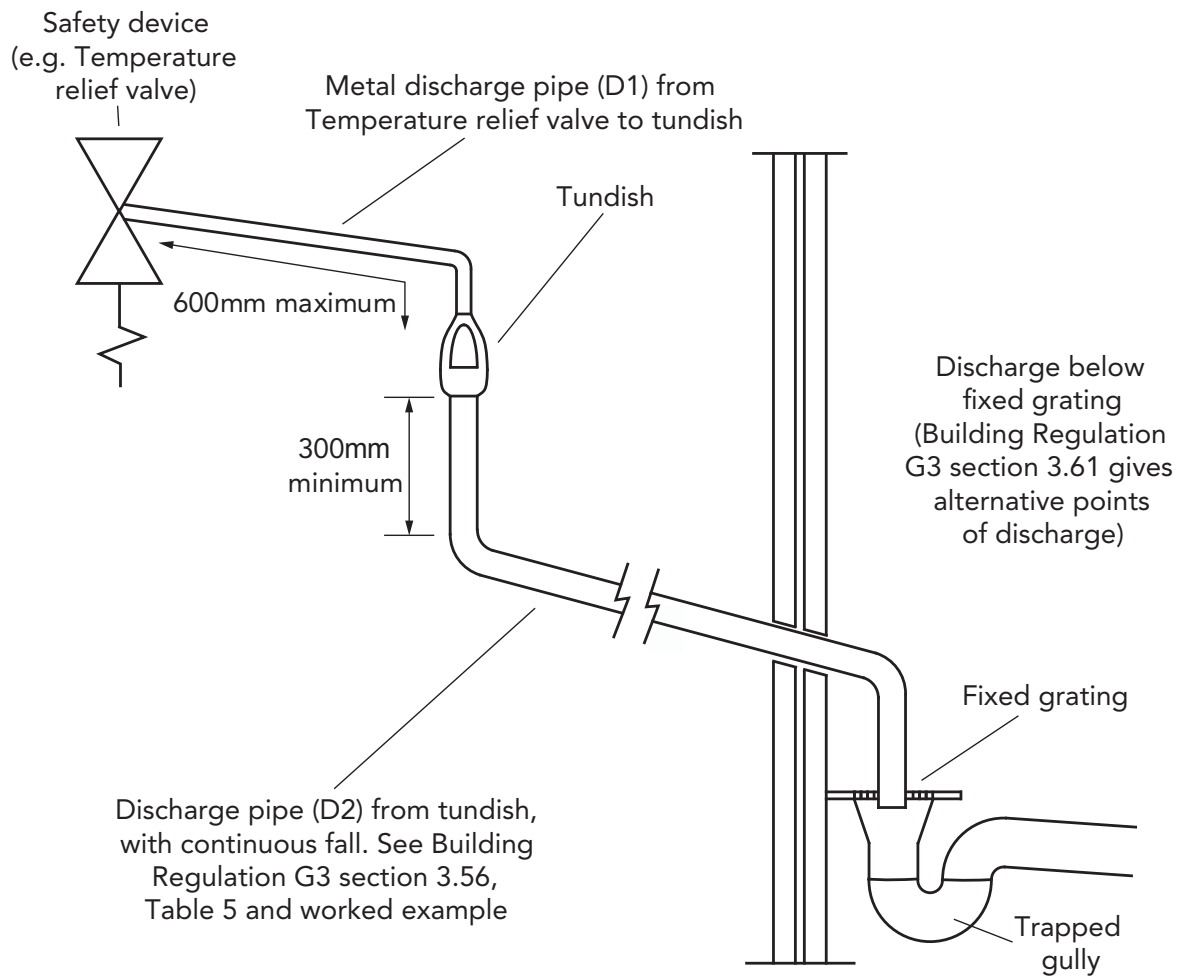

Figure 10: Typical discharge pipe arrangement (extract from Building Regulation G3 Guidance Section 3.50)

6.3 Electrical connections

In case of difficulty contact service support; contact details are available on page 28 of this booklet.



WARNING

- ▶ Disconnect from the mains electrical supply before removing any covers.
- ▶ Never attempt to replace the immersion heater(s) other than with genuine manufacturers components. Using other manufacturers components may invalidate the warranty on the cylinder.
- ▶ DO NOT bypass the thermal cut-out(s) in any circumstances. All electrical wiring should be carried out by a competent electrician and be in accordance with the latest I.E.E Wiring Regulations.
- ▶ Each circuit must be protected by a suitable fuse and double pole isolating switch with a contact separation of at least 3mm in both poles.
- ▶ DO NOT operate the immersion heaters until the cylinder has been filled with water.

- ▶ The immersion heater(s) should be wired in accordance with fig 4 & 5, page 9.

Space and heating systems controls

- ▶ The controls provided with the cylinder will ensure the safe operation of the unit within the central heating system. Other controls will be necessary to control the space heating requirements and times that the system is required to function.
- ▶ The cylinder is compatible with most heating controls, examples of electrical circuits are shown in figs. 2 and 3, page 8. However, other systems may be suitable, refer to the controls manufacturers instructions, supplied with the controls selected, for alternative system wiring schemes.

6.4 Filling the installation

- ▶ Check expansion vessel pre-charge pressure. The vessel is supplied precharged to 3.5 bar to match the control pressure of the pressure reducing valve. The precharge pressure is checked using using a car tyre gauge by unscrewing the plastic cap opposite the water connection.
- ▶ Check all connections for tightness including the immersion heater(s). An immersion heater key spanner is supplied for this purpose.
- ▶ Ensure the drain cock is CLOSED.
- ▶ Open a hot tap furthest from the cylinder.
- ▶ Open the mains stop cock to fill the unit. When water discharges from the tap, allow to run for a few minutes to thoroughly flush through any residue, dirt or swarf, then close the tap.
- ▶ Open successive hot taps to purge the system of air.

7. Commissioning

7.1 General

After filling the installation with water in the previous section please follow the following steps to complete the installation of the unit.



WARNING

DO NOT operate the immersion heaters or primary circuit until the cylinder has been filled with water.

7.2 Checklist before commissioning

- ▶ Check all water connections for leaks and rectify as necessary.
- ▶ Turn off mains water supply.
- ▶ Remove the pressure reducing valve head work to access the strainer mesh, clean and re-fit.
- ▶ Turn the water supply back on.
- ▶ Manually open, for a few seconds, each relief valve in turn, checking that water is discharged and runs freely through the tundish and out at the discharge point.
- ▶ Ensure that the valve(s) reseal satisfactorily.

7.3 Commissioning procedure

Direct units

- ▶ Switch on electrical supply to the immersion heater(s) and allow the cylinder to heat up to normal working temperature (60 - 65°C recommended).

- ▶ If necessary the temperature can be adjusted by inserting a flat bladed screwdriver in the adjustment spindle on front of the immersion heater thermostat and rotating. The adjustment represents a temperature range of 12°C to 72°C.
- ▶ Check the operation of thermostat(s) and that no water has discharged from the expansion relief valve or temperature/pressure relief valve during the heating cycle.

Indirect units

- ▶ Fill the indirect (primary) circuit following the boiler manufacturer's commissioning instructions.
- ▶ To ensure the cylinder primary heat exchanger is filled, the 2 port motorised valve (supplied) should be manually opened by moving the lever on the motor housing to the MANUAL setting. When the primary circuit is full return the lever to the AUTOMATIC position.
- ▶ Switch on the boiler, ensure the programmer is set to Hot Water and allow the cylinder to heat up to a normal working temperature (60 - 65°C recommended).
- ▶ If necessary the temperature can be adjusted by inserting a flat bladed screwdriver in the adjustment knob and rotating. The minimum thermostat setting is 10°C. The maximum thermostat setting is 72°C.



WARNING

- ▶ If the unit is to be left unused following installation and commissioning e.g. unoccupied properties, the water heater should be drained or regularly flushed through with fresh mains water once a week.
- ▶ When placing the unit into service, the procedure for filling the unit and the system checks above should be observed.

THERMAL CUT-OUT RESET BUTTON

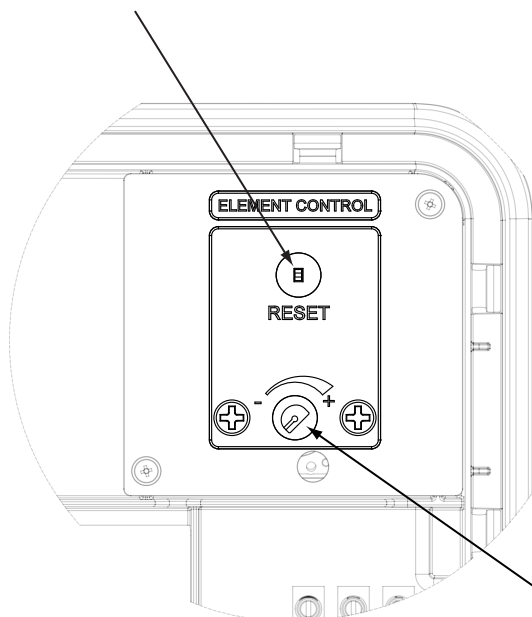

SPINDLE POSITIONS

⏪ = MINIMUM TEMP

⏩ = MAXIMUM TEMP

🔧 = APPROX 60 °C

ROTATE SPINDLE CLOCKWISE FOR TEMPERATURE INCREASE AND COUNTER CLOCKWISE FOR TEMPERATURE DECREASE

TEMPERATURE ADJUSTING SPINDLE

Figure 11: Direct controls

8. Operation

8.1 General



WARNING

- ▶ If water discharges from the temperature/pressure relief valve on the cylinder shut down the heat source. Do not turn off any water supply. Contact a competent installer for unvented water heaters to check the system.
- ▶ Do not tamper with any of the safety valves fitted to the system. If a fault is suspected contact a competent installer.
- ▶ DO NOT bypass the thermal cut-out(s) in any circumstances.

Benchmark

The cylinder is covered by the Benchmark Scheme which aims to improve the standards of installation and commissioning of domestic heating and hot water systems in the UK and to encourage regular servicing to optimise safety, efficiency and performance.

Benchmark is managed and promoted by the Heating and Hotwater Industry Council. For more information visit www.centralheating.co.uk.

Please ensure that the installer has fully completed the Benchmark Checklist (page 25) of this manual and that you have signed it to say that you have received a full and clear explanation of its operation. The installer is legally required to complete a commissioning checklist as a means of complying with the appropriate Building Regulations (England & Wales).

All installations must be notified to Local Area Building Control either directly or through a Competent Persons Scheme. A Building Regulations Compliance Certificate will then be issued to the customer who should, on receipt, write the Notification Number on the Benchmark Checklist.

This product should be serviced regularly to optimise its safety, efficiency and performance. The service engineer should complete the relevant Service Record on the Benchmark Checklist after each service.

The Benchmark Checklist may be required in the event of any warranty work.

Flow performance

When initially opening hot outlets a small surge in flow may be noticed as pressures stabilise. This is quite normal with unvented systems. In some areas cloudiness may be noticed in the hot water. This is due to aeration of the water, is quite normal and will quickly clear.

Temperature controls – direct units immersion heater(s)

- ▶ All immersion heaters are fitted with a combined thermostat and thermal cut-out located under the terminal cover mounted on the side of the product.
- ▶ Access to the thermostat can be made by opening the immersion heater cover - DISCONNECT THE ELECTRICAL SUPPLY BEFORE OPENING THE COVER(S).
- ▶ Temperature adjustment is made by inserting a flat bladed screwdriver in the slot on the adjustment disc on top of the thermostat and rotating. The adjustment represents a temperature range of 12°C to 72°C. Figure 11, page 19.
- ▶ Maximum working temperature is 72°C/154°F. In very hard water areas limit to 60/65°C (140/150°F).

DO NOT bypass the thermal cut-out(s) in any circumstances.

Temperature controls - indirect units

- ▶ The cylinder units are fitted with an indirect thermostat and thermal cut-out. These controls must be wired in series with the 2 port motorised zone valve supplied to interrupt the flow of primary water around the heat exchanger coil when the control temperature has been reached.
- ▶ The controls are located within the lower terminal housing along with the immersion heater thermostat. The thermostat is factory set to give a water storage temperature of approx 55°C to 60°C.
- ▶ Access to the thermostat can be made by opening the terminal housing cover. DISCONNECT THE ELECTRICAL SUPPLY BEFORE OPENING THE COVER.
- ▶ Temperature adjustment is made by inserting a flat bladed screwdriver in the adjustment knob and rotating. The minimum thermostat setting is 12°C, The maximum thermostat setting is 72°C.

DO NOT bypass the thermal cut-out(s) in any circumstances.

Operational faults

Operational faults and their possible causes are detailed in the Fault Finding section (p.22) of this book. It is recommended that faults should be checked by a competent installer.

The air volume within the expansion vessel will periodically require recharging to ensure expanded water is accommodated within the system. A discharge of water INTERMITTENTLY from the expansion valve will indicate the air volume has reduced to a point where it can no longer accommodate the expansion. This will require a suitably qualified person to check the expansion vessel pressure and no attempt should be made to re-pressurize the expansion vessel by the end user.

9. Maintenance

9.1 General

Maintenance requirements

Unvented hot water systems have a continuing maintenance requirement in order to ensure safe working and optimum performance. It is essential that the relief valve(s) are periodically inspected and manually opened to ensure no blockage has occurred in the valves or discharge pipework. Maintenance of this appliance should only be carried out by a suitably qualified person. Failure to do so could invalidate the warranty.

Similarly cleaning of the strainer element and replacement of the air in the expansion vessel will help to prevent possible operational faults.

The maintenance checks described below should be performed by a competent person on a regular basis, e.g. annually to coincide with boiler maintenance.

After any maintenance, please complete the relevant Service Interval Record section of the Benchmark Checklist on page 26 of this document.

9.2 Standard inspection & maintenance operations

Inspection

The immersion heater boss can be used as an access for inspecting the cylinder internally.

Safety valve operation



CAUTION

Water discharged may be very hot!

- ▶ Manually operate the temperature/pressure relief valve for a few seconds.
- ▶ Check water is discharged and that it flows freely through the tundish and discharge pipework.
- ▶ Check valve reseats correctly when released.
- ▶ Repeat the above procedure for the expansion relief valve.

Strainer

- ▶ Turn off the isolating valve prior to the Pressure Reducing Valve or the main stop cock to the system.
- ▶ Open the lowest hot tap in the system to relieve the system pressure.
- ▶ Using a spanner unscrew the pressure reducing cartridge and remove the moulded housing. The strainer will be removed with the cartridge.
- ▶ Wash any particulate matter from the strainer under clean running water.
- ▶ Replace the strainer and screw the Pressure Reducing Valve cartridge into the moulded housing.
- ▶ Close hot tap, turn on isolating valve or main stop cock to the system. Check for leaks.

- ▶ Descaling immersion heater(s)
- ▶ Turn off the mains water supply, isolate the electrical supply and turn off boiler
- ▶ Attach a hosepipe to the drain cock having sufficient length to take water to a suitable discharge point below the level of the unit.
- ▶ Open a hot tap close to the unit and open drain cock to drain unit. If water fails to drain vent the unit manually by opening the temperature and pressure relief valve.
- ▶ Open the cover(s) to the immersion heater housing(s) and disconnect wiring from immersion heater(s).
- ▶ Unscrew the immersion heater backnut(s) and withdraw the immersion heater from the cylinder. A key spanner is supplied with the product for easy removal and tightening of the immersion heater(s). Over time the immersion heater gasket may become stuck to the mating surface. To break the seal insert a round shafted screwdriver into one of the pockets on the immersion heater and gently lever up and down. Take care when lifting the immersion heater out of the cylinder and work within safe working practices.
- ▶ Carefully remove any scale from the surface of the element(s).



CAUTION

DO NOT use a sharp implement as damage to the element surface could be caused.

- ▶ Ensure sealing surfaces are clean and seals are undamaged, if in doubt fit a new gasket. (spare part number 70 351 65)
- ▶ Replace immersion heater(s), making sure not to trap the gasket.
- ▶ Rewire, check, close and secure immersion heater housing cover(s).

Re-commissioning

- ▶ Check all electrical and plumbing connections are secure. Close the drain cock.
- ▶ With a hot tap open, turn on the cold water supply and allow unit to refill.
- ▶ DO NOT switch on the immersion heater(s) or boiler until the unit is full.
- ▶ When water flows from the hot tap allow to flow for a short while to purge air and flush through any disturbed particles.
- ▶ Close hot tap and then open successive hot taps in system to purge any air.
- ▶ When completely full and purged check system for leaks.
- ▶ The heating source (immersion heater(s) or boiler) can then be switched on

Expansion vessel charge pressure

- ▶ Remove the dust cap on top of the vessel. Check the charge pressure using a tyre pressure gauge. The pressure (system de-pressured) should be 0.35MPa (3.5 bar). If it is lower than the required setting it should be re-charged using a tyre pump (schrader valve type). DO NOT OVER-CHARGE. Re-check the pressure and when correct replace the dust cap.

10. Troubleshooting



WARNING

Do not tamper with any of the safety valves or controls supplied with the cylinder as this will invalidate any guarantee.

10.1 Fault finding

Important

- ▶ After servicing, complete the relevant Service Interval Record section of the Benchmark Checklist located on pages 25 and 26 of this document.
- ▶ Servicing should only be carried out by competent persons in the installation and maintenance of unvented water heating systems.
- ▶ Any spare parts used MUST be authorised parts.
- ▶ Disconnect the electrical supply before removing any electrical equipment covers.
- ▶ NEVER bypass any thermal controls or operate system without the necessary safety valves.

- ▶ Water contained in the cylinder may be very hot, especially following a thermal control failure. Caution must be taken when drawing water from the unit.

The fault finding chart (table 6, below) will enable operational faults to be identified and their possible causes rectified. Any work carried out on the unvented water heater and its associated controls MUST be carried out by a competent installer for unvented water heating systems. In case of doubt contact service support.

Spare Parts

A full range of spare parts are available for the cylinder range (table 7, page 23). Refer to the technical data label on the unit to identify the model installed and ensure the correct part is ordered. You will need to quote the serial number, which is printed on the data label.

Fault	Possible Cause	Remedy
No hot water flow	Mains water supply off	Check and open stop cock
	Strainer blocked	Turn off water supply. Remove strainer and clean
	Cold water combination valve incorrectly fitted	Check and refit as required
Water from hot tap is cold	Direct immersion heater not switched on	Check and switch on
	Direct immersion heater thermal cut-out has operated	Check, reset by pushing button on thermostat
	Indirect programmer set to central heating only	Check, set to domestic hot water programme
	Indirect boiler not working	Check boiler operation. If fault is suspected consult boiler manufacturer's instructions
	Indirect thermal cut-out has operated	Check, reset by pushing button on thermostat. Check operation of indirect thermostat
Water discharges from expansion valve	Intermittently Expansion vessel charge pressure has reduced below 3.5bar, or set to high	See Maintenance section (p.21) for re-charging of expansion vessel procedure
	Continually Cold water combination valve pressure reducer not working correctly. Expansion valve seat damaged	Check pressure from cold water combination valve. If greater than 3.5bar replace pressure reducing valve cartridge. Remove expansion valve cartridge, check condition of seat. If necessary fit new expansion valve
Water discharges from T&P relief valve	Thermal control failure CAUTION: Water will be very hot!	Switch off power to immersion heater(s) and shut down boiler. DO NOT turn off water supply. When discharge stops check all thermal controls, replace if faulty
Milky water	Oxygenated water	Water from a pressurised system releases oxygen bubbles when flowing. The milkiness will disappear after a short while

Table 6: Fault finding chart

11. Decommissioning

11.1 Decommissioning procedure

- ▶ Isolate electrical supplies and make safe
- ▶ Isolate the water supply
- ▶ Drain the cylinder
- ▶ Drain the primary circuit (indirect only)
- ▶ Remove cylinder
- ▶ Cap pipework

12. Spare parts

12.1 Spare parts list

A full range of spare parts are available for the cylinder range. Refer to the Technical Data label on the unit to identify the model installed and ensure the correct part is ordered.

	DESCRIPTION	SPARES NUMBER
1	Immersion heater (lower)	95606984
2	Immersion heater (upper)	95606986
3	Immersion heater gasket	70 351 65
4	Immersion heater backnut	95607869
5	Immersion heater key - not shown	95607861
6	Tundish - not shown	95605838
7	Expansion valve - 6bar	70 360 62
8	Cold water combination valve complete	70 344 68
9	Pressure reducing valve cartridge 3.5 bar	70 360 63
10	Temperature/Pressure Relief Valve	95605810
11	Expansion vessel 12 litre (100,120 and 150 litre models) - not shown	95607863
12	Expansion vessel 18 litre (170 and 210 litre models) - not shown	95607864
13	Expansion vessel 24 litre (250 and 300 litre models) - not shown	95607612
14	Blanking plate assembly - not shown	95605881
15	Nut & olive pack (4 of each) - not shown	95607838
16	Direct combined Thermostat and Thermal cut-out	95612717
17	Indirect combined Thermostat and Thermal cut-out	95612716
18	6 way terminal block	95607933
19	3 way terminal block	95607932
20	2 port motorised valve (22mm connections) - not shown	95605819
21	Terminal shroud	95 606 993
22	Control Cover	95 614 137

Table 7: Spares

Environmental information

Products are manufactured from many recyclable materials. At the end of their useful life they should be disposed of at a Local Authority Recycling Centre in order to realise the full environmental benefits.

Insulation is by means of an approved CFC/HCFC free polyurethane foam with an ozone depletion factor of zero.

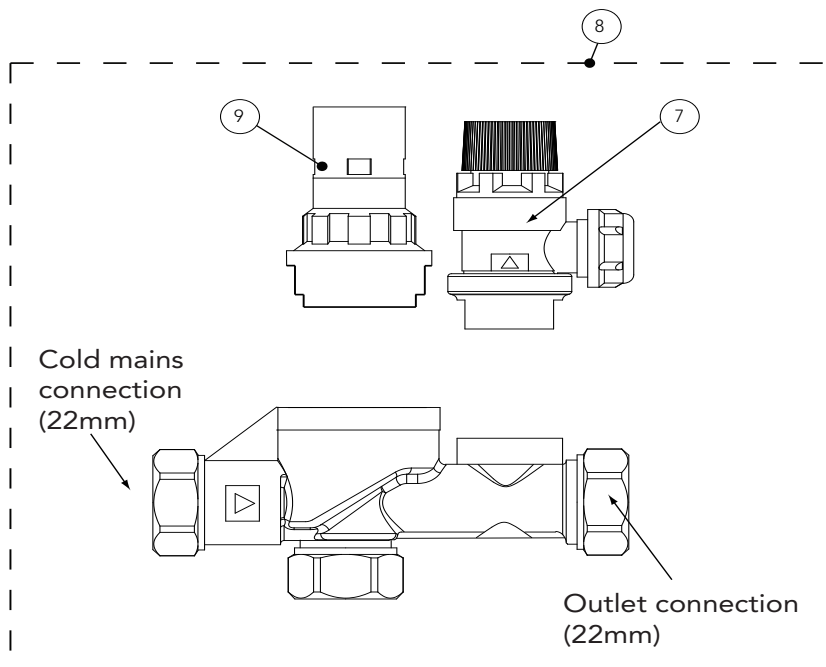

Figure 12: Exploded view of cold water combination valve

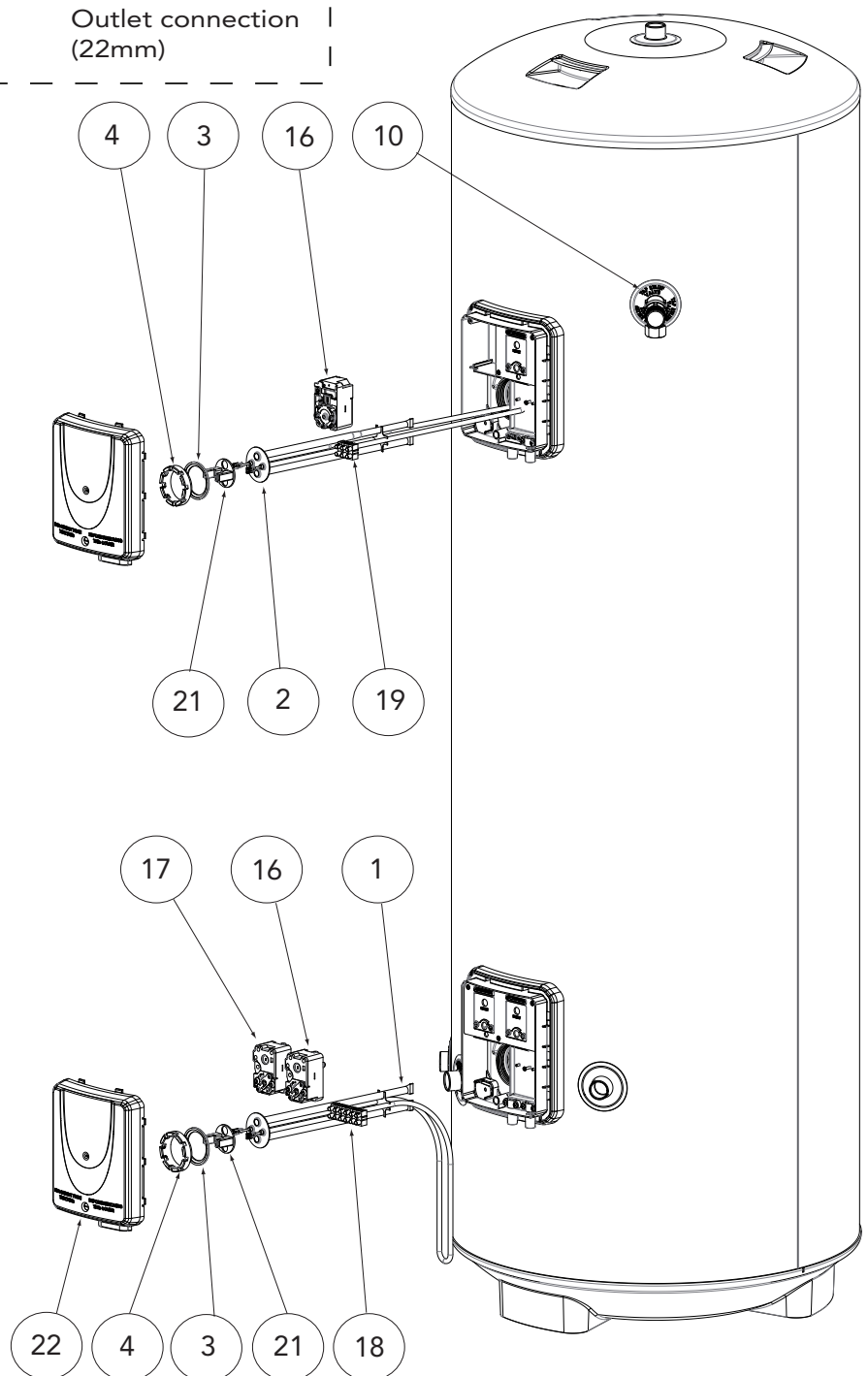

Figure 13: Cylinder exploded view

MAINS PRESSURE HOT WATER STORAGE SYSTEM COMMISSIONING CHECKLIST

This Commissioning Checklist is to be completed in full by the competent person who commissioned the storage system as a means of demonstrating compliance with the appropriate Building Regulations and then handed to the customer to keep for future reference.

Failure to install and commission this equipment to the manufacturer's instructions may invalidate the warranty but does not affect statutory rights.

Customer name:		Telephone number:	
Address:			
Cylinder Make and Model			
Cylinder Serial Number			
Commissioned by (PRINT NAME):		Registered Operative ID Number	
Company name:		Telephone number:	
Company address:			
		Commissioning date:	
To be completed by the customer on receipt of a Building Regulations Compliance Certificate*:			
Building Regulations Notification Number (if applicable)			
ALL SYSTEMS PRIMARY SETTINGS (indirect heating only)			
Is the primary circuit a sealed or open vented system?		Sealed	Open
What is the maximum primary flow temperature?			°C
ALL SYSTEMS			
What is the incoming static cold water pressure at the inlet to the system?			bar
Has a strainer been cleaned of installation debris (if fitted)?		Yes	No
Is the installation in a hard water area (above 200ppm)?		Yes	No
If yes, has a water scale reducer been fitted?		Yes	No
What type of scale reducer has been fitted?			
What is the hot water thermostat set temperature?			°C
What is the maximum hot water flow rate at set thermostat temperature (measured at high flow outlet)?			l/min
Time and temperature controls have been fitted in compliance with Part L of the Building Regulations?		Yes	
Type of control system (if applicable)		Y Plan	S Plan Other
Is the cylinder solar (or other renewable) compatible?		Yes	No
What is the hot water temperature at the nearest outlet?			°C
All appropriate pipes have been insulated up to 1 metre or the point where they become concealed		Yes	
UNVENTED SYSTEMS ONLY			
Where is the pressure reducing valve situated (if fitted)?			
What is the pressure reducing valve setting?			bar
Has a combined temperature and pressure relief valve and expansion valve been fitted and discharge tested?		Yes	No
The tundish and discharge pipework have been connected and terminated to Part G of the Building Regulations		Yes	
Are all energy sources fitted with a cut out device?		Yes	No
Has the expansion vessel or internal air space been checked?		Yes	No
THERMAL STORES ONLY			
What store temperature is achievable?			°C
What is the maximum hot water temperature?			°C
ALL INSTALLATIONS			
The hot water system complies with the appropriate Building Regulations		Yes	
The system has been installed and commissioned in accordance with the manufacturer's instructions		Yes	
The system controls have been demonstrated to and understood by the customer		Yes	
The manufacturer's literature, including Benchmark Checklist and Service Record, has been explained and left with the customer		Yes	
Commissioning Engineer's Signature			
Customer's Signature			
(To confirm satisfactory demonstration and receipt of manufacturer's literature)			

*All installations in England and Wales must be notified to Local Authority Building Control (LABC) either directly or through a Competent Persons Scheme. A Building Regulations Compliance Certificate will then be issued to the customer.



SERVICE RECORD

It is recommended that your hot water system is serviced regularly and that the appropriate Service Record is completed.

Service Provider

Before completing the appropriate Service Record below, please ensure you have carried out the service as described in the manufacturer's instructions.

SERVICE 01		Date:	SERVICE 02		Date:
Engineer name:			Engineer name:		
Company name:			Company name:		
Telephone No:			Telephone No:		
Email Address:			Email Address:		
Comments:			Comments:		
.....				
.....				
.....				
Signature			Signature		
SERVICE 03		Date:	SERVICE 04		Date:
Engineer name:			Engineer name:		
Company name:			Company name:		
Telephone No:			Telephone No:		
Email Address:			Email Address:		
Comments:			Comments:		
.....				
.....				
.....				
Signature			Signature		
SERVICE 05		Date:	SERVICE 06		Date:
Engineer name:			Engineer name:		
Company name:			Company name:		
Telephone No:			Telephone No:		
Email Address:			Email Address:		
Comments:			Comments:		
.....				
.....				
.....				
Signature			Signature		
SERVICE 07		Date:	SERVICE 08		Date:
Engineer name:			Engineer name:		
Company name:			Company name:		
Telephone No:			Telephone No:		
Email Address:			Email Address:		
Comments:			Comments:		
.....				
.....				
.....				
Signature			Signature		
SERVICE 09		Date:	SERVICE 10		Date:
Engineer name:			Engineer name:		
Company name:			Company name:		
Telephone No:			Telephone No:		
Email Address:			Email Address:		
Comments:			Comments:		
.....				
.....				
.....				
Signature			Signature		

Warranty

Guarantee Terms and Conditions

WARNING: Should the factory fitted temperature and pressure relief valve be tampered with or removed your guarantee will be invalidated. Neither the Distributor nor Manufacturer shall be responsible for any consequential damage howsoever caused.

Warranty Terms

Heatrae Sadia warranty guarantees the water heater cylinder against faulty manufacture or materials for a period of two years from the date of purchase including parts and labour. This two year warranty is extended to five years for the cold water control valve and to 30 years for the stainless steel inner vessel.

These guarantees are valid provided that:

- The water heater has been installed by a competent engineer and as per the instructions contained in the installation manual and all relevant Codes of Practice and Regulations in force at the time of installation.
- Any disinfection has been carried out in accordance with BS EN 806-5:2012
- Should the factory fitted temperature and pressure relief valve be tampered with or removed your guarantee will be invalidated.
- The water heater has not been modified in anyway other than by our approved engineers.
- The water heater has only been used for the storage of wholesome sanitary water (max 250mg/l chloride).
- The water heater unit has not been subjected to excessive pressure beyond the guidelines detailed in the installation instructions.
- The water heater unit has not been subjected to frost, nor has it been tampered with or been subject to misuse or neglect.
- No factory fitted parts have been removed for un-authorized repair or replacement.
- The Benchmark™ commissioning checklist service record included in this product guide has been completed.
- Regular maintenance has been carried out by a competent person in accordance with the requirements set in the maintenance section of the installation manual and any replacement parts used should be approved spare parts.
- Within 60 days of purchase the owner completes and returns the certificate supplied to register the product. Evidence of purchase and date of supply must be submitted upon making a claim.
- The guarantee is not valid outside of the United Kingdom.

The warranty does NOT cover:

Damage caused as a result of scale

Consequential damages or profit loss which may arise from a defect.

Warranty claims have no delaying effect on the payment dates and other demands

Your water heater warranty covers you for a direct replacement and labour in the event that the unit fails prematurely as a result of a proved manufacturing defect.

In order that this can be achieved, full access to replace the unit is essential. If it is found that access can not be achieved the warranty will be limited to the replacement of the unit only and subsequent labour charges would not be met under the warranty.

For installations outside of the United Kingdom, please contact either the Heatrae Sadia Export Department on Tel: +44 1603 420271 or Baxi International on Tel: +44 1926 478323 for further details of the guarantee terms and conditions applicable. This guarantee does not affect your statutory rights.

HEATRAESADIA

SMARTER | CLEANER | WARMER

Electric Water Heating Co.

2 Horsecroft Place
Pinnacles
Harlow
Essex CM19 5BT
Tel: 0845 0553811
E-Mail: sales@ewh.co.uk

SPD

Special Product Division
Units 9 & 10
Hexagon Business Centre
Springfield Road
Hayes
Middlesex UB4 0TY
Tel: 020 8606 3567

Parts Center

Tel: 0344 292 7057
www.partscenter.co.uk

Newey & Eyre

Unit 3-5 Wassage Way
Hampton Lovett Ind. Estate
Droitwich, Worcestershire
WR9 0NX
Tel: 01905 791500
Fax: 01905 791501

UK Spares Ltd

Unit 1155
Aztec West
Almondsbury
Bristol BS32 4TF
Tel: 01454 620500

Alternatively contact your local supplying merchant or wholesale branch or use our online stockist finder at www.interpartspares.co.uk

SPECIFICATION ADVICE HOTLINE

t | 01603 420220 e | specifier@heatraesadia.com

AFTER SALES SERVICE

t | 0344 871 1535 e | heatraesadiaservice@heateam.co.uk

w | heatraesadia.com



OUR NATIONWIDE NETWORK OF CUSTOMER SUPPORT ENGINEERS

Heatrae Sadia has its very own dedicated nationwide network of highly trained customer support engineers so you can have peace of mind that we're always here to help.

PRODUCT RANGE

Full specification details on all our products are available to download from our website.

To support our corporate responsibility and sustainability charters and reduce our printed material we encourage you to download product brochures from our website.

In designing these files we have taken into account the need to access data on screen.

If you would like to receive a printed copy of our full product catalogue please call our literature hotline on 01603 420127.

Heatrae Sadia Heating may introduce modifications to their products from time to time. Consequently, the details given in this brochure are subject to alteration without notice.

The HWA Charter's Code of Practice requires that all members adhere to the following:

- To supply fit for purpose products clearly and honestly described
- To supply products that meet, or exceed appropriate standards and building and water regulations
- To provide pre and post sales technical support
- To provide clear and concise warranty details to customers

Please follow us online:



PN 7032982 Issue 04
© Heatrae Sadia 2015